

PHILIPS EFFICIA CART



3-0048



Ergonomic

Simple, lightweight, easy to use



Smooth and easy to clean surfaces

Quick and easy cleaning



Multi purpose

Large range of accessories to improve the functionality



Durable

Lifetime Warranty



Quick and easy assembly



Accessories



Handle and Storage
(Part Number.: ST5-C5)



Rubber inserts
(Part Number.: 1-0051)



Large Basket
(Part Number.: ST2-C5)



Handle
(Part Number.: H1-C5)



Cable Hook
(Part Number.: CH1-C5)



Storage Bin
(Part Number.: ST3-C5)

Pictures are illustration and accessories are not included in the standard configuration.

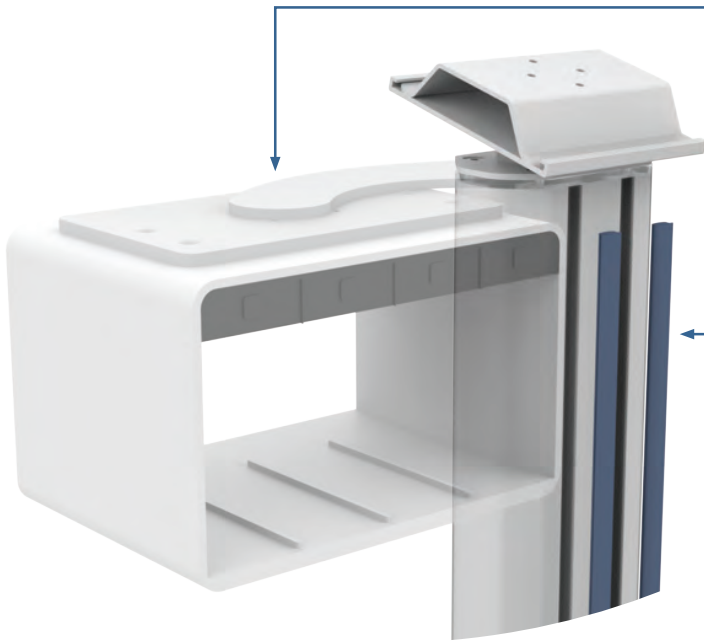

Optional EFF Holder.
(Part Number.: 1-0257)

Optional Rubber inserts
(Part Number.: 1-0051)

Monitor Holder

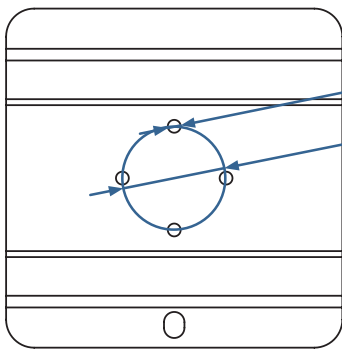



Ø 4,6 mm (x4)

Ø 37 mm



Optional Handle and Storage

Specifications

Mechanical Data	
Height	1117 mm
Base dimension	616 mm (diameter)
Wheel construction	Polyamide with Polyurethane tread
Wheels / Locking	4 lockable, 100 mm diameter
Loading capacity	20 kg
Construction	
Main assembly	Aluminium
Color	
RAL 9016	
Custom Color	
Certificates	
Certificates conforms to	IEC60601-1:2012 (Edition 3)
CE	Rohs compliant

Technical characteristics

- Fully recyclable
- Lifetime Warranty
- Made in Hungary

