

# Lumify Cart

3-0027



## Ergonomic

Simple, light weight, easy to use



## Smooth and easy to clean surfaces

Quick and easy cleaning



## Multi purpose

Customise with a choice of accessories



## Durable

Lifetime Warranty\*



## Quick setup

Supplied fully assembled with minimal packaging



**Gel Holder**



**9-11" Tablet Mount**

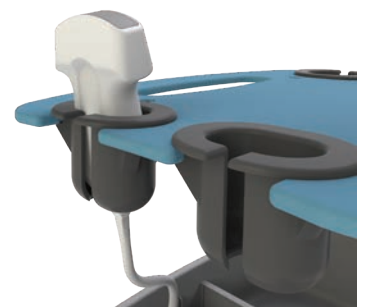

**Scanner Holder**



*Lock with key*

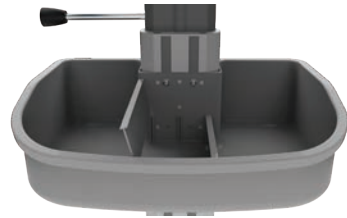

*Optional Storage*

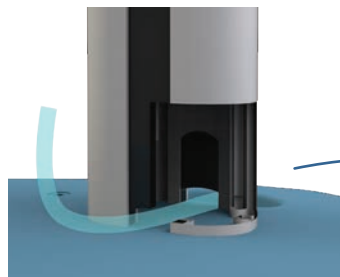

*Cable Management*

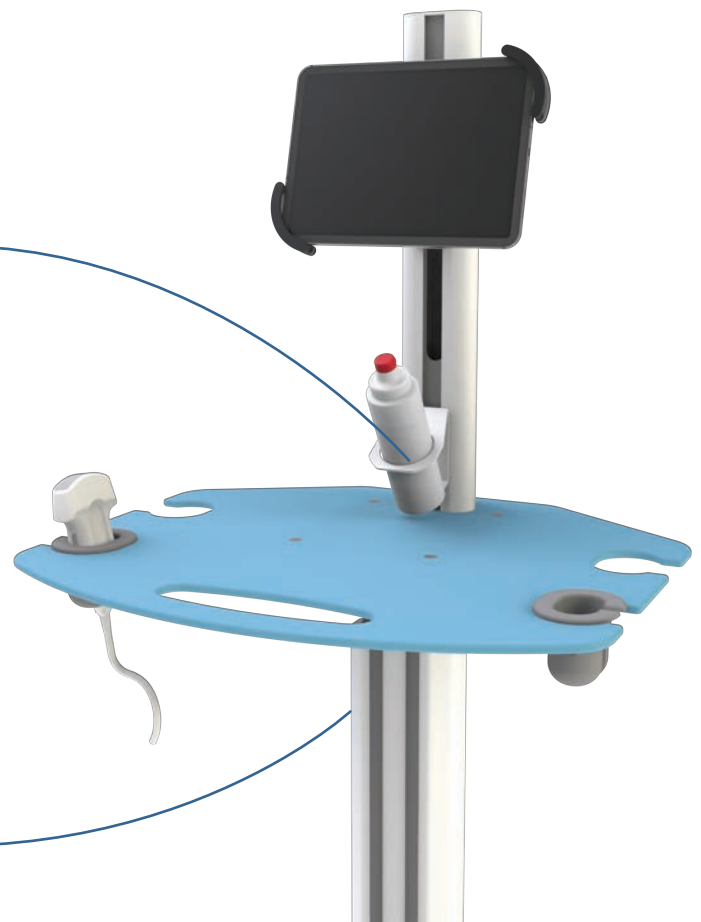

*Height Adjustable*

# Specifications

## Mechanical data

Work Surface height	Min: 760mm Max: 1110mm
Base dimension	616mm (diameter)
Wheel construction	Polyamide with Polyurethane tread
Wheels/locking	4 lockable, 100mm diameter
Loading capacity	20 kg

## Construction

Main assembly	Aluminium
---------------	-----------

## Color

RAL 9016	
Custom color	

## Accessories options

ST3 Storage Bin

ST2 Basket

CH1 Cable Hook

## Certificates

Certificates conforms to	IEC60601-1:2012 (Edition 3)
CE	Rohs compliant

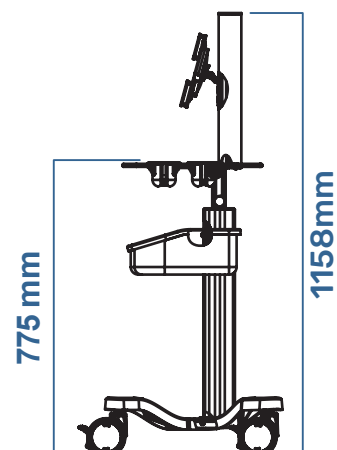
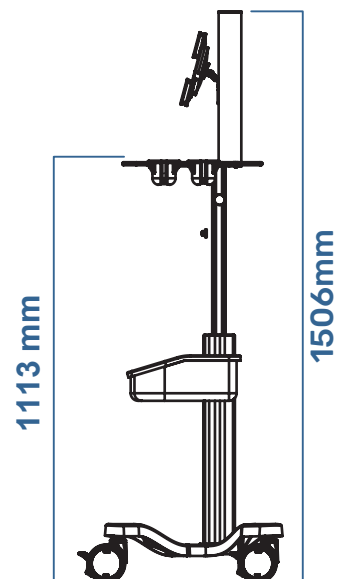

## Technical characteristics

- Fully recyclable
- Lifetime Warranty\*
- Made in Hungary

