

PHILIPS MX/MP ARM

3-0046



Ergonomic

Simple, lightweight, easy to use



Smooth and easy to clean surfaces

Quick and easy cleaning



Durable

Lifetime Warranty



Quick and easy assembly



Accessories



Cable Hook
(Part Number.: 1-0250)

Specifications



Mechanical Data	
Height	200 mm
Wall Mounting Height	134 mm
Arm length	260 mm
Construction	
Main assembly	Aluminium
Color	
RAL 9016	
Certificates	
Certificates conforms to	IEC60601-1:2012 (Edition 3)
CE	Rohs compliant

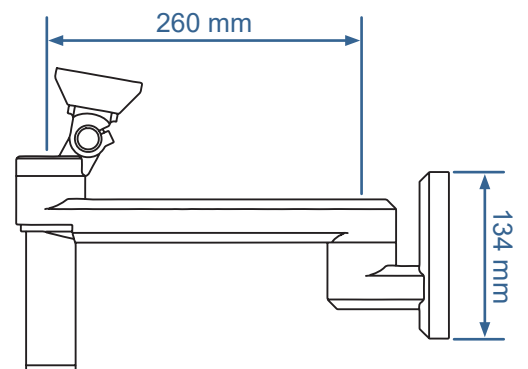
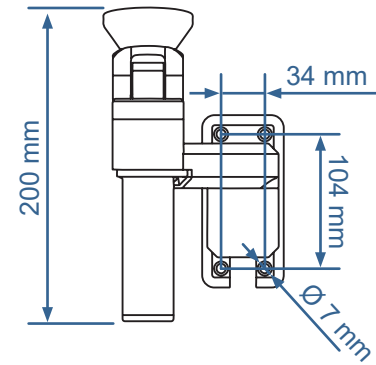

Technical characteristics

- Fully recyclable
- Lifetime Warranty
- Made in Hungary



Philips mounting Pins - Not included in the kit

